



Rewarding Learning

General Certificate of Secondary Education

Centre Number

--	--	--	--	--

Candidate Number

--	--	--	--

# Further Mathematics

Unit 4 (With calculator)

Discrete and  
Decision Mathematics



[GFM41]

\*GFM41\*

Assessment

Assessment Level of Control:

Tick the relevant box (✓)

TIME

1 hour.

Controlled Conditions	
Other	

### INSTRUCTIONS TO CANDIDATES

Write your Centre Number and Candidate Number in the spaces provided at the top of this page.

**You must answer the questions in the spaces provided.**

**Do not write outside the boxed area on each page.**

Complete in black ink only. **Do not write with a gel pen.**

All working **must** be clearly shown in the spaces provided. Marks may be awarded for partially correct solutions.

Answer **all six** questions.

### INFORMATION FOR CANDIDATES

The total mark for this paper is 50.

Figures in brackets printed down the right-hand side of pages indicate the marks awarded to each question or part question.

You may use a calculator.



1 Kevin, a tour operator, offers package holidays to a particular hotel in a resort in Spain.

The package holidays are either self-catering or half-board.

Let  $x$  be the number of self-catering holidays and  $y$  the number of half-board holidays booked.

The total number of holidays cannot exceed 80

(i) Write down an inequality, in terms of  $x$  and  $y$ , to express this condition.

Answer \_\_\_\_\_ [1]

To keep his contract with the hotel, Kevin must ensure that there are at least 20 self-catering holidays and at least 15 half-board holidays booked.

(ii) Write down two inequalities to express these conditions.

Answer \_\_\_\_\_  
\_\_\_\_\_ [2]

Kevin pays a handling fee of £5 per self-catering holiday and £8 per half-board holiday.

He must ensure that the total amount for handling fees is at least £240

(iii) Write down an inequality to express this condition.

Answer \_\_\_\_\_ [1]



(iv) Illustrate the four inequalities by a suitable diagram on the graph below.

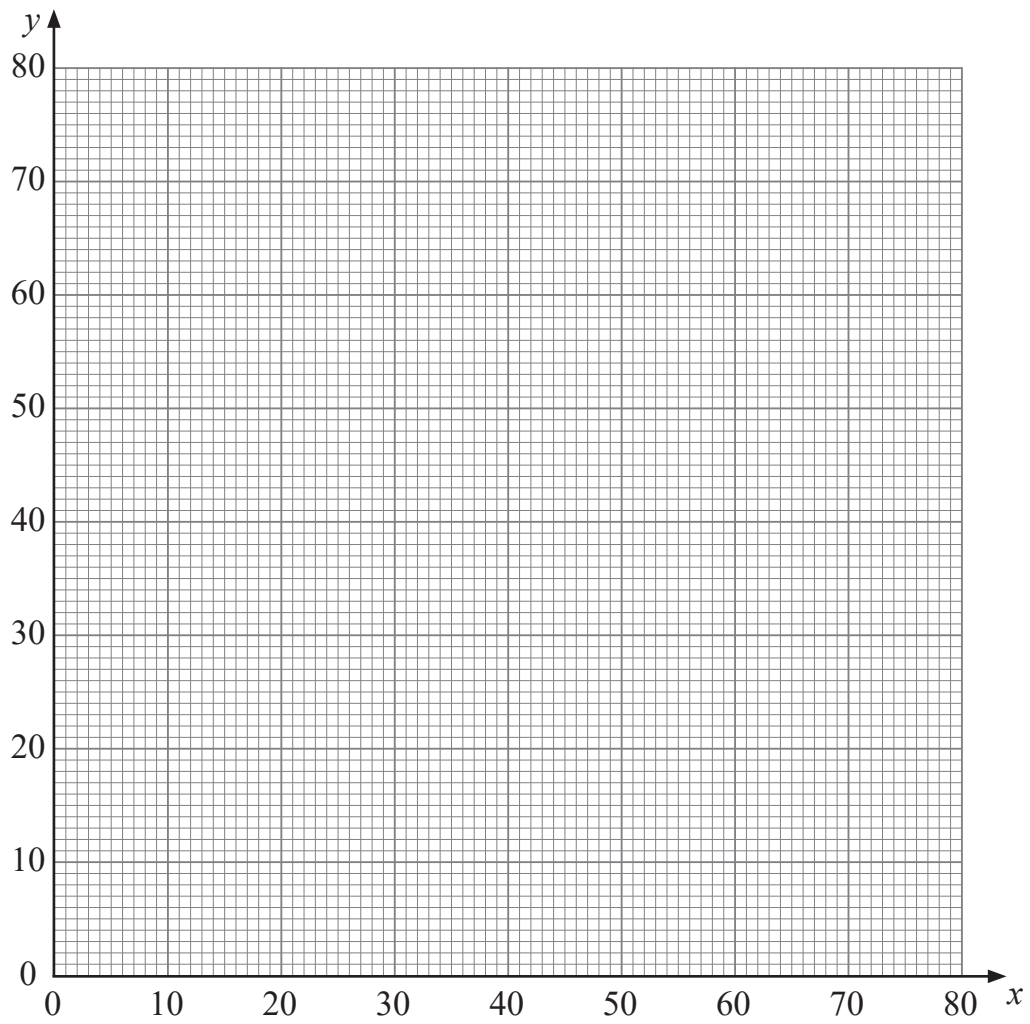

Identify with the letter **R** the region containing the set of points satisfying all four inequalities.

[3]

Q1 continues on page 5

[Turn over



**BLANK PAGE**  
**DO NOT WRITE ON THIS PAGE**

Q1 continues on opposite page

12429.02 R



\*20GFM4104\*



Kevin makes a net profit of  
£60 for each self-catering holiday booked, and  
£50 for each half-board holiday booked.

- (v) Write down an expression, in terms of  $x$  and  $y$ , for Kevin's net profit  $P$ , in pounds.

Answer  $P =$  \_\_\_\_\_ [1]

- (vi) Calculate the maximum net profit that Kevin can make.

Answer £ \_\_\_\_\_ [3]

[Turn over

12429.02 R



\*20GFM4105\*

- 2 (a) A teacher randomly gives 15 tickets for a concert to a class containing 20 students.

No student is given more than one ticket.

Find the number of ways in which this can be done.

Answer \_\_\_\_\_ [2]



(b) The Year 14 in St Swithin's has 11 Mentors.

A Captain, a Secretary and a Chairperson, as well as three Prefects, must be chosen from the 11 Mentors.

Find the number of ways in which this can be done, given that no one can hold more than one position.

Answer \_\_\_\_\_ [4]

[Turn over



- 3 The table below shows the number of drivers caught speeding by a speed control unit over a 12-week period.

Week	1	2	3	4	5	6	7	8	9	10	11	12
Number of drivers	37	29	38	42	34	26	32	35	32	23	25	30

These data have been plotted in the graph below.

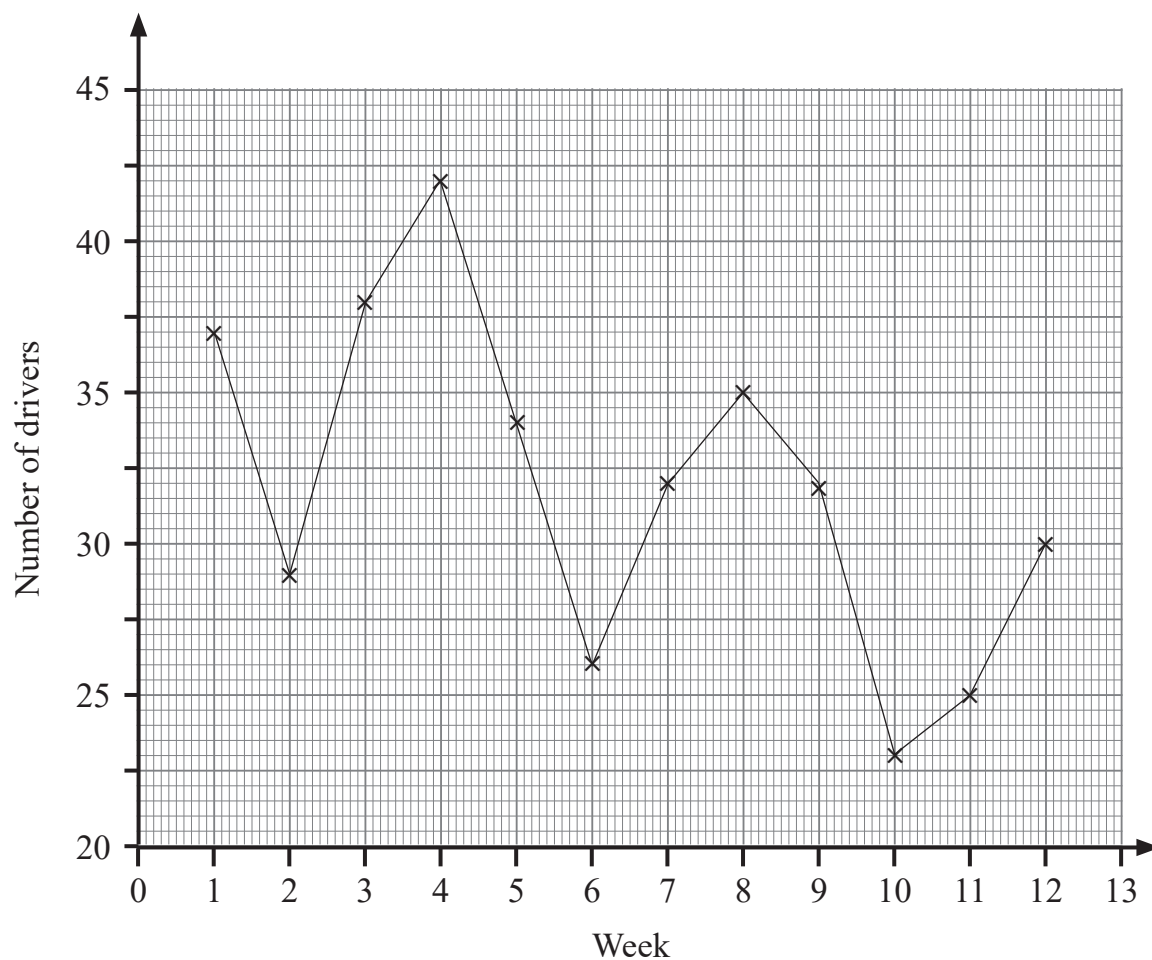

(i) Calculate appropriate moving averages to smooth the data, using the information below.

37

29

38

42

34

26

32

35

32

23

25

30

[3]

(ii) Plot these averages on the graph opposite and draw the trend line.

[3]

Q3 continues on page 11

[Turn over

12429.02 R



\*20GFM4109\*

**BLANK PAGE**  
**DO NOT WRITE ON THIS PAGE**

Q3 continues on opposite page

12429.02 R



\*20GFM4110\*



(iii) Showing clearly where any reading is taken, use the trend line to estimate how many drivers are likely to be stopped in week 13

Answer \_\_\_\_\_ [3]



- 4 In the quiz show “Only One Winner” two contestants, Peter and Quinn, play against each other.

A contestant only wins a point if they get a question correct and their opponent gets the same question wrong.

The Boolean variables  $p$  and  $q$  have the values

$p$  is true when Peter gets a question correct,

$q$  is true when Quinn gets a question correct.

Thus, if Peter wins a point, then the Boolean expression

$p$  and not  $q$

is true.

- (i) Write down a Boolean expression that is true when Quinn wins a point.

Answer \_\_\_\_\_ [1]

- (ii) Write down a Boolean expression that is true when either contestant wins a point.

Answer \_\_\_\_\_ [2]



(iii) By filling in the truth tables below, show that the Boolean expression in (ii) is equivalent to

**not ( $p$  and  $q$ ) and ( $p$  or  $q$ )**

					Expression from (i)	Expression from (ii)
$p$	$q$	not $p$	not $q$	$p$ and not $q$		
T	T					
T	F					
F	T					
F	F					

$p$	$q$	$p$ and $q$	not ( $p$ and $q$ )	$p$ or $q$	not ( $p$ and $q$ ) and ( $p$ or $q$ )
T	T				
T	F				
F	T				
F	F				

[7]

[Turn over



5 To qualify for a government subsidy, Fred must plant on his farm:

Either 2 out of 6 grain crops,  
3 out of 7 root vegetables, and  
1 out of 8 green vegetables;

Or 1 out of 6 grain crops,  
4 out of 7 root vegetables, and  
2 out of 8 green vegetables.

Find the number of ways in which Fred may plant out his farm.

Answer \_\_\_\_\_ [6]





**BLANK PAGE**  
**DO NOT WRITE ON THIS PAGE**  
**(Questions continue overleaf)**

**[Turn over**

12429.02 R



\*20GFM4115\*

6 The diagram below shows the activity network used to model a building project.

The activities are labelled A, B, ..., L and are represented by the edges.

The number in brackets on each edge represents the time, in weeks, required for one employee to complete that activity.

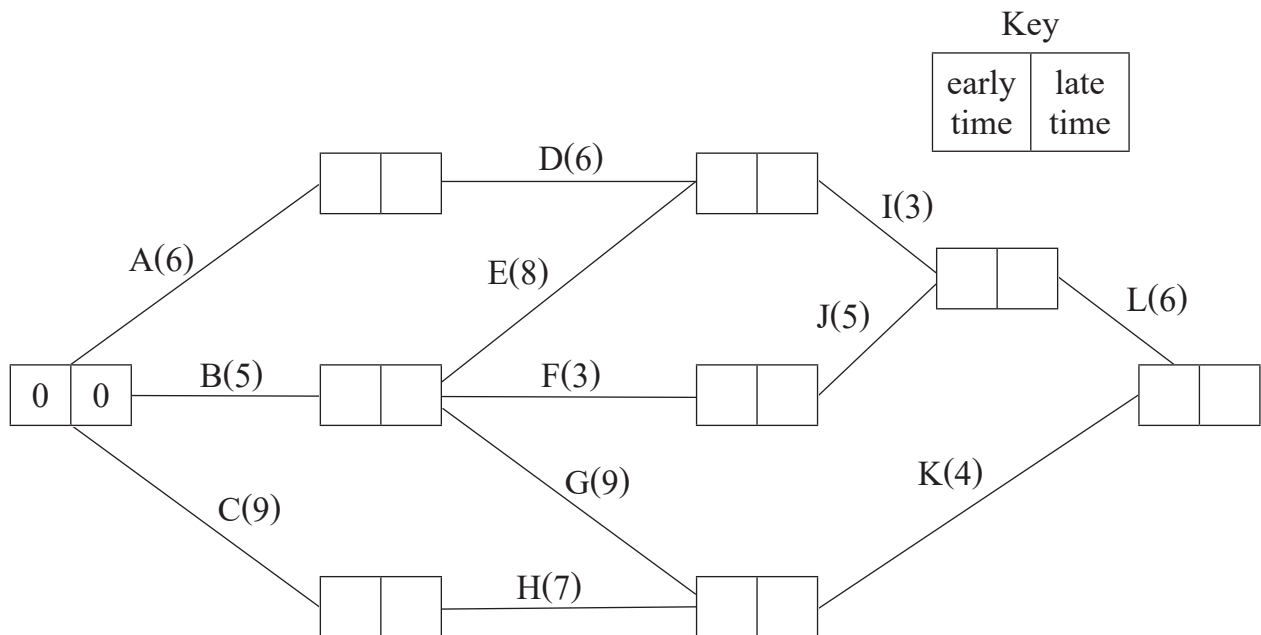

(i) Complete the diagram above by filling in the missing early times and late times.

[4]

(ii) Calculate the float times of activities F and H.

Answer Float time of F \_\_\_\_\_ weeks

Float time of H \_\_\_\_\_ weeks [2]



(iii) List the critical activities and determine the length of the critical path.

Answer Critical activities \_\_\_\_\_ [1]

Length of critical path \_\_\_\_\_ weeks [1]

---

**THIS IS THE END OF THE QUESTION PAPER**

---



**BLANK PAGE**  
**DO NOT WRITE ON THIS PAGE**

12429.02 R



\*20GFM4118\*





**BLANK PAGE**  
**DO NOT WRITE ON THIS PAGE**

12429.02 R



\*20GFM4119\*

**DO NOT WRITE ON THIS PAGE**

For Examiner's use only	
Question Number	Marks
1	
2	
3	
4	
5	
6	

<b>Total Marks</b>	
--------------------	--

Examiner Number

Permission to reproduce all copyright material has been applied for.  
In some cases, efforts to contact copyright holders may have been unsuccessful and CCEA  
will be happy to rectify any omissions of acknowledgement in future if notified.

12429.02 R



\*20GFM4120\*